

# RDUK DELIVERY SERVICE



**RDUK**  
ROOFING DISTRIBUTION UK

# VEHICLE OPTIONS / SERVICE

At RDUK, we are committed to providing a reliable and efficient haulage service to support all your roofing projects. We offer a wide range of vehicles to suit any site and any order size. Whether you need a small, quick delivery or a large, complex haul, we have the right vehicle for the job. Our team is always available to assist with scheduling, tracking, and any other logistical needs. We prioritize clear communication and customer satisfaction at every step of the process.

## 28T FLATBED ARTIC (NO OFFLOAD)



Without the weight of a crane to carry, these lorries carry our heaviest loads making them the most economic where void or palletized loads need to be delivered.

Max load weight = 29 tonnes  
Bed length (approx.) = 12.2m

This vehicle is CrossRail Compliant. For more information please contact us.

## 28T CURTAIN-SIDED



The 28-tonne curtain-sided lorry features durable, weather-resistant curtains for easy side loading and unloading and a flatbed design for maximum cargo space

Max load weight = 28 tonnes  
Bed length (approx.) = 13.6 meters  
Maximum vehicle height = 4.5 meters

## 28T DRAWBAR WITH CRANE OFFLOAD



The draw bar with crane carries more than the rigid vehicle and if required can be split by dropping the trailer to gain access to almost any site. Despite its overall length of 17.5 metres (57'4") it is therefore ideal for very tight sites where the economy of large loads can be maximized, therefore reducing unit cost for the customer.

Max load weight = 28 tonnes  
Bed 1 length (approx.) = 6.6m  
Bed 2 length (approx.) = 5.64m  
Maximum vehicle height = 3.72m  
Crane capacity at 6.6m from the lorry (approx.) = 1.62 tonnes

## 18T RIGID WITH CRANE OFFLOAD



The eight-wheeled rear mount rigid crane carries 18 tonnes and can get into almost any site. The advantage of having a rear-mounted crane means you have the flexibility of where the product can be placed on site.

Max load weight = 18 tonnes  
Bed 1 length (approx.) = 8.3m  
Maximum vehicle height = 3.66m  
Crane capacity at 8.8m from the lorry (approx.) = 1.2 tonnes

## 6-WHEELER WITH CRANE OFFLOAD



The six-wheeled rear-mounted crane is ideal for smaller loads or tighter access. The advantage of having a rear mounted crane means you have the flexibility of where the product can be placed on site.

Max load weight: 12.5 tonnes  
Bed 1 length (approx.) 6.6m  
Bed 2 length (approx.) 3.72m  
Maximum vehicle height: 3.72m  
Crane capacity at 6.6m from the lorry (approx.) 1.62 tonnes

# DELIVERY SERVICE

## PALLET NETWORK COURIER SERVICE

For the smallest of deliveries, we offer a courier service with pump truck and tail lift offload. This service has a 1-tonne weight restriction. Their designated size and weight limitations are as follows:



**FULL PALLET: MAX WEIGHT 1250KG**

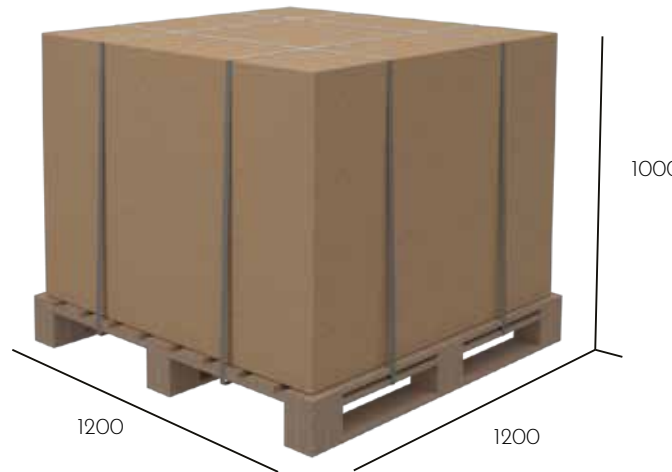

**HALF PALLET: MAX WEIGHT 500KG**

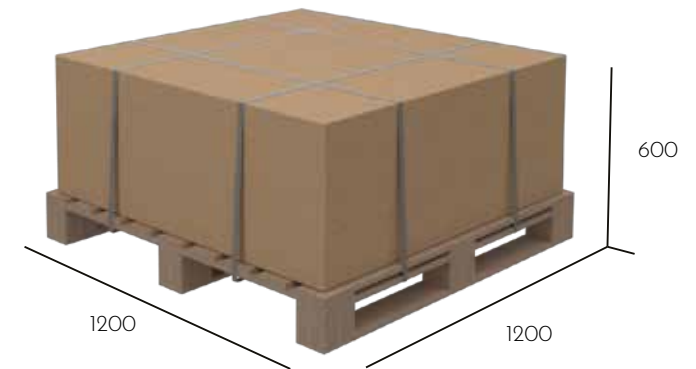

**QUARTER PALLET: MAX WEIGHT 250KG**

## FREE SAMPLE DELIVERY SERVICE

To ensure that you make an informed decision on your tile choice, we offer a complimentary sample delivery service allowing you to examine the quality and suitability of our products first-hand, ensuring they meet your exact specifications before placing your order.

Having browsed our extensive product range, select the samples you're interested in, and we'll courier them directly to your site or office at no cost.

Enquire today: [sales@roofingdistributionuk.com](mailto:sales@roofingdistributionuk.com) / 01375 397 140